

**Investigating the Mediating Role of Green Intention between Green Attitude-Behaviour Gap****Dr. Vishal Gupta****ABSTRACT**

This study examines the influence of various cultural and psychological factors on the green purchase behavior of young Indian consumers. For this, a conceptual model has been proposed and subjected to empirical verification with the use of a survey. The survey results obtained in three major Indian universities provide reasonable support for the validity of the proposed model. The study found that green attitude of young consumers directly leads to their green intention and their attitudes toward green products, in turn, are also seen to affect their green purchase behavior via the mediator of green purchase intention. This study also discusses how the present findings may help the Indian government and green marketers to fine-tune their environmental programs.

**1. Introduction**

“Green” is the buzzword that is gaining huge popularity among the present generation, 87% of people from various nations like Brazil, Canada, China, France, Germany, India, the UK and the US have shown an interest in reducing their impact on the environment (Mitra, D. 2014). The overall market for green marketing is said to be worth \$ 3.5 trillion by the year 2017, according to a report by Global Industry Analysts Inc. of 2013 (Mitra, 2014). Despite the great amount of awareness and knowledge on green marketing, the market share of green products is still significantly small, only 38% pay more for green products, although 72% of the respondents were aware about the green products available in the market (Rakesh and Lakshmi, 2015). Around the world, consumers are becoming more and more environment conscious and this rising consciousness can be attributed to their own observation and widespread media reporting of environmental problems like earthquakes and floods in many parts of the world, hurricanes, storms and advancing climate change. Today’s consumers have started to realise that their purchasing behavior actually can cause a huge impact to the environment and began to buy products and services from companies with good environmental reputation base. Now consumers are showing rising interest towards the environmental issues and want to translate their cognitive optimistic green attitude and intention to the ultimate green purchase behavior i.e. the actual action to buy some green product which means consumption of those products which are not harmful for the environment (Chen & Chai, 2010). According to Ajzen’s Theory of Planned Behavior (1991) consumers’ attitudes leads toward purchase behavior through purchase intention.

**2. Literature Review**

During the last two decades, the burgeoning environmental movement was named as the “green movement”, environmentally aware consumers called the “green consumers”, product designed to protect the environment called the “green products” and marketing that uses the environmental claims called the “green marketing” (Peattie, 1992). Environmental concerns had a direct, positive influence on green purchase attitude, suggesting that consumers who possess strong environmental concern may be interested in consumption of products that reflect that concern Kim (2007).

D’Souza, c., Taghian, M., & Khosla, R. (2007) explained that consumer attitude appears to be that they are less likely to compromise on product quality than on somewhat higher prices of green products. Consumers’ awareness on products marketed in green marketing is important in guiding their purchasing decision of green products, as consumers’ awareness of price and brand image significantly influenced their purchasing decision of green products (Suki, M.N. 2013). Consumers’ intentions to purchase green product are strong as their attitudes toward, green advertising are positive and the firms should stress their environmental actions, which will allow consumers to differentiate between “green” firms and “non-green” firms as green products are in demand (Zhu, 2013). Dr. Anand. B, (2015) the demographical and psychological variables can be used to understand the environment conscious consumer behaviour and further stated that psychographic variables are much comfortable for explain the green consumer behaviour than demographic variables. Psychographic factors are for example social class, political orientation, personality characteristics and altruism. More than 80% of global online consumers say that it is important that companies should produce products that are energy efficient and the use of recyclable packaging materials (Ming et al.). The most significant factors found under green product attributes were personal benefit, price, convenience of use, performance, availability, concern for environment and health concern (Dr. Mahapatra, S. 2013). Many studies show that the attitude-behaviour relationship has been strengthened when attitudes towards performing specific environmentally friendly behaviour (e.g., recycling), rather than towards general environmental issues. Green behavioural intentions are influenced by the person’s beliefs, the social pressure to conform to the wishes of others or so called subjective norms and their perceived ability to carry out the action which is also called perceived

behavioural control (Pastiu, 2013). The purchase intention of consumers is influenced by psychographic variables, personal norms and social norms (Kumar, K.P., and Anand, B. 2013). Many literatures about environmental behaviour mostly speaking about environmental behaviour in general, a few have been addressed specifically about green purchasing behaviour. According to Chen (2013) green loyalty and green satisfaction are important factors for building green brand equity. Green product quality likely influence green customer satisfaction and green customer loyalty and green customer satisfaction had potential impact on green customer loyalty (Asgharian, R., Salehi, M., Saleki, S.Z., Hojabri, R., &Nikkheslat, M. (2012).

**3. The Proposed Model**

With reference to the conceptual framework, a conceptual model was proposed in Figure 1 to explain Generation Y green attitude and behaviour.

**Figure 1: The Proposed Model**

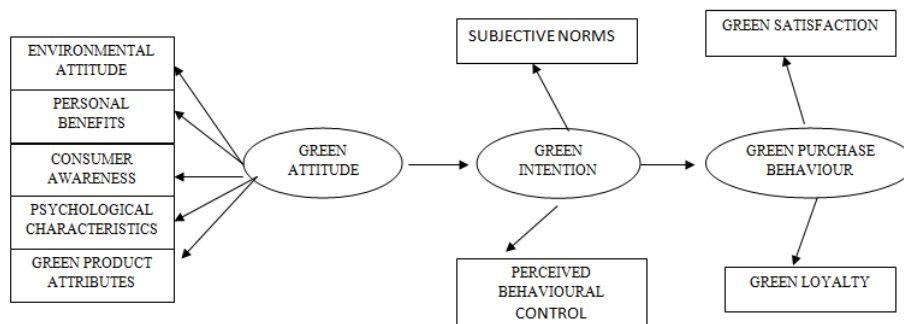

**4. Research Design and Methodology**

In order to make the study more perfect and objective, following steps have been taken:

**4.1 Generation of Scale Items**

The statements of questionnaire were self-structured and decided after reviewing the existing literature and consulting the experts and green product users. Each questionnaire is sub-divided into 2 parts, part I comprised of general information and specific information asked in open-ended & close-ended and dichotomous questions and part II comprised of statements in 5-point Likert scale, where 1 denotes ‘strongly disagree’ and 5 denotes ‘strongly agree’. The questionnaire for the P.G students consist of 95 items, 9 questions pertaining to the general information, 6 for specific information, 22 for environmental attitude, 21 for consumers awareness 17 for psychological characteristics and 20 for green product attributes.

**4.2 Sample and Response Rate**

Data was collected through the distribution of self-structured questionnaires to the 350 P.G students of University of Jammu on convenience basis criteria using green products during the last one year, out of which 302 (86.29%) have given response.

**5. DATA ANALYSIS**

**5.1 Exploratory Factor Analysis**

For the scale purification, the multivariate statistical technique of factor analysis is used with the help of SPSS (17.0). Principal Component Analysis (PCA) along with Varimax rotation (Stewart, 1981) is used to simplify the columns in a factor matrix by looking at whether underlying assumptions are met in Eigen values (>1), communalities (>.50) and factor loadings (>.50). Kaiser-Meyer-Olkin (KMO) is used to verify the appropriateness of factor analysis, where value greater than .50 is acceptable, between .50 to .70 is mediocre and .70 to .80 is good, .80 to .90 is great and above .90 is superb (Malhotra, 2007). Further, Bartlett test of Sphericity is used to determine correlation among variables (Wong et al. 2009). PCA has been run dimension-wise, in order to extract factors for further analysis and all the factors & items are eligible for acceptance with Eigen-value (>1), communalities (>0.50) and factor loadings (>0.50).

After using factor analysis the 165 items were reduced to 132 items. Under the construct green attitude, the dimension ‘Environmental attitude’ is split into six factors namely, ‘Environmental awareness’ with variance explained (16.68%), ‘Environmental problems’ with variance explained (14.44%), ‘Environmental protection’ with variance explained (12.70%), ‘Environmental degradation’ with variance explained (10.52%), ‘Environmental initiatives’ with variance explained (10.09%) and

'Environmental concern' with variance explained (9.49%), personal benefits split into five factors namely, 'Personal satisfaction' with variance explained (23.66%), 'Health benefits' with variance explained (15.14%), 'Beneficial to Humanity' with variance explained (13.97%) and 'Pure natural ingredients' with variance explained (11.74%), four factors are emerged under the dimension 'Consumer awareness' namely, 'Green advertising' with 18.75% variance explained, 'Individual's nature awareness' with 14.36% variance explained, 'Eco-labels' with 12.59% variance explained and 'Green movement' with 11.03% variance explained, psychological characteristics split into four factors namely, 'Unselfishness', 'Future-oriented', 'Altruism' and 'Perceived consumer effectiveness' with 19.93%, 14.02%, 13.77% and 12.20% variance explained, respectively and under dimension 'Green product attributes', five factors are emerged namely, 'Eco-friendly and healthy contents" with 17.26% variance explained, 'Economical' with 15.86% variance explained, 'Good taste and quality' with 15.72% variance explained, 'Energy-efficient' with 14.09% and 'Green packaging' with 12.51% variance explained. Under the second construct green intention, dimension 'Subjective norms' generates four factors namely, 'Family views', 'Peer group influence', 'Social expectations' and 'Reference group views' with variance explained 25.04%, 16.29%, 12.49% and 10.92% variance explained respectively and under the second dimension i.e. perceived behavioural control four factors are emerged namely, 'Green information', 'Ability to buy', 'Time' and 'Lack of availability' with 40.06%, 28.88% & 21.34% respectively. Finally under the third construct the dimension 'Green satisfaction' split into four factors namely namely, 'Social contribution' with the 19.39% variance explained, 'Monetary benefits' with the 16.21% variance explained, 'Health benefits' with the 15.83 variance explained and 'Environmental benefits' with 14.92% variance explained and under the dimension green loyalty five factors are emerged namely, 'Green performance', 'Green advise', 'Green choice', 'Green commitments' and 'Green habit' with 19.98%, 14.89%, 13.77%, 12.18% and 11.99% variance explained respectively.

## 5.2 Scale Validation- Confirmatory Factor Analysis

Exploratory Factor Analysis (EFA) explores the data and provides the researcher with the information about how many factors are needed to best represent the data. CFA statistics tells us how well our specification of the factors matches reality (the actual data). It is a tool that enables us to either confirm or reject our preconceived theory. CFA is used to provide a confirmatory test and validation of our measurement theory. Under the construct green attitude, the dimension Environmental attitude is measured by the six factors emerged in EFA with thirteen items. In CFA, two factors which include five items are deleted because of lower regression weights (less than .50), personal benefits have got the 12 items with four factors, consumer awareness left with 12 items, psychological characteristics left 9 items under 3 factors, green product attributes left with 11 items and 4 factors. Under the construct green intention, subjective norms left with 9 items and 3 factors and perceived behavioural control are left with 9 items and 3 factors. Under the construct green purchase behaviour after applying CFA, the dimension green satisfaction left with 11 items and green loyalty also left with 11 items.

## 6. Structural Equation Modelling

After confirming factors through CFA and assessing their validity & reliability, the next step performed is SEM for hypotheses testing. A structural theory is a conceptual representation of the relationships between constructs. On the basis of SEM results, the framed hypotheses have been tested and the results are as under:

**H1:** Youths' attitude toward green products directly leads to intention to buy green products.

The structural model II also fitted well as depicted by chi-square/df statistics= 3.962, GFI= 0.987, AGFI= 0.946, RMR= 0.036, RMSEA= 0.54, NFI= 0.964, TLI= 0.939 and CFI= 0.955 (Table 3). The SEM results also depict that youths' green attitude directly leads to youths' green intention which is predicted through subjective norms and perceived behavioural control ( $\beta = 0.80, p < .05$ ) (Fig. 1). Thus, H1a stands accepted. The results are also favoured by other authors (Chen, 2007; Kalafatis et al., 1999; Lodorfos et al., 2008; Robinson et al., 2002; Tarkiainen et al., 2005; Vermeir, 2007 & Zainudin, 2013).

Figure 1: Structural Model I

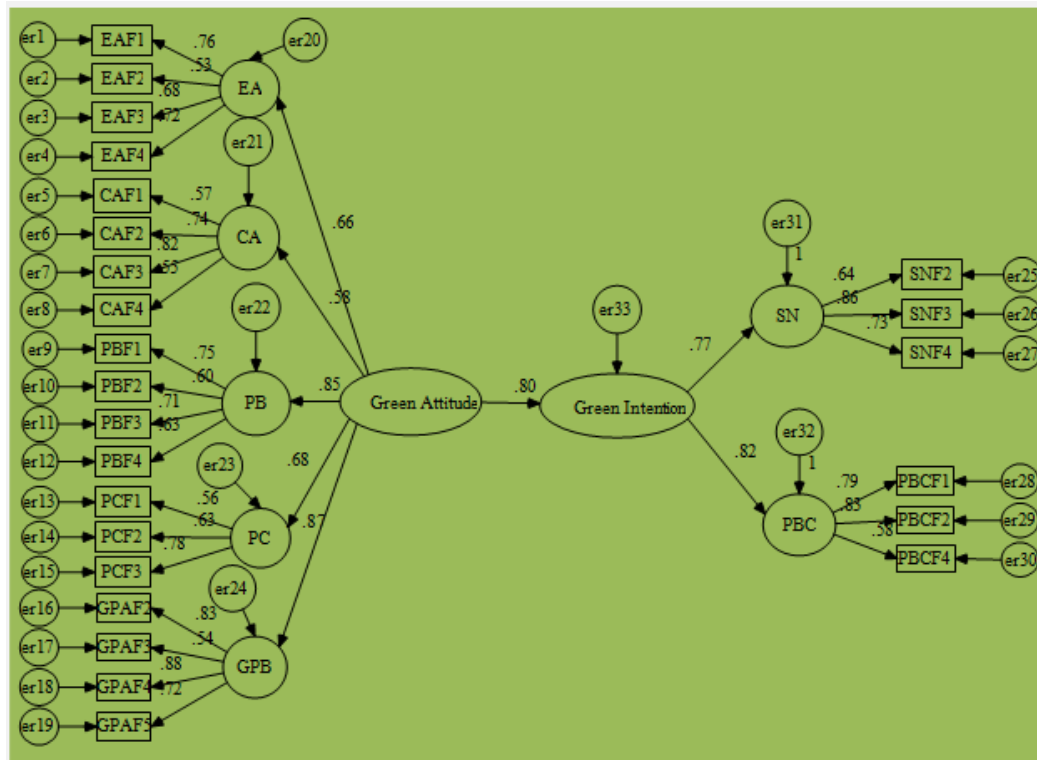

**Notes:** EA = Environmental attitude, EAF1= Environmental awareness, EAF2= Environmental problems, EAF3= Environmental protection, EAF4= Environmental degradation, CA= Consumer awareness, CAF1= Green advertising, CAF2= Individual’s nature awareness, CAF3= Eco-labels, CAF4= Green movement, PB= Personal benefits, PBF1= Personal satisfaction, PBF2= Health benefits, PBF3= Beneficial to humanity, PBF4= Pure natural ingredients, PC= Psychological characteristics, PCF1=Unselfishness, PCF2= Future-oriented, PCF3= Altruism, GPA= Green products attributes, GPAF2= Economical, GPAF3= Good taste and quality, GPAF4= Energy-efficient, GPAF5= Green packaging, SN= Subjective norms, SNF2= Peer group influence, SNF3= Social expectations, SNF4= Reference group views, PBC= Perceived behavioural control, PBCF1= Green information, PBCF2= Ability to buy, PBCF4= Availability of products and er1-er33= error terms

**H2:** Youths’ green intention to buy green products directly leads to green purchase behaviour.

The structural model V also fitted well as depicted by chi-square/df statistics= 4.734, GFI= 0.968, AGFI= 0.922, RMR= 0.032, RMSEA= 0.064, NFI= 0.951, TLI= 0.915 and CFI= 0.960 (Table 3). The SEM results also depict that green intention to buy green products directly leads to green purchase behaviour ( $\beta = 0.64, p < .05$ ) (Fig. 2). Thus, H2b stands accepted. The results are also favoured by other authors (Vazifehdoust et al., 2013; Anvar et al., 2014 & Joshi and Rahman, 2015).

Figure 2: Structural Model II

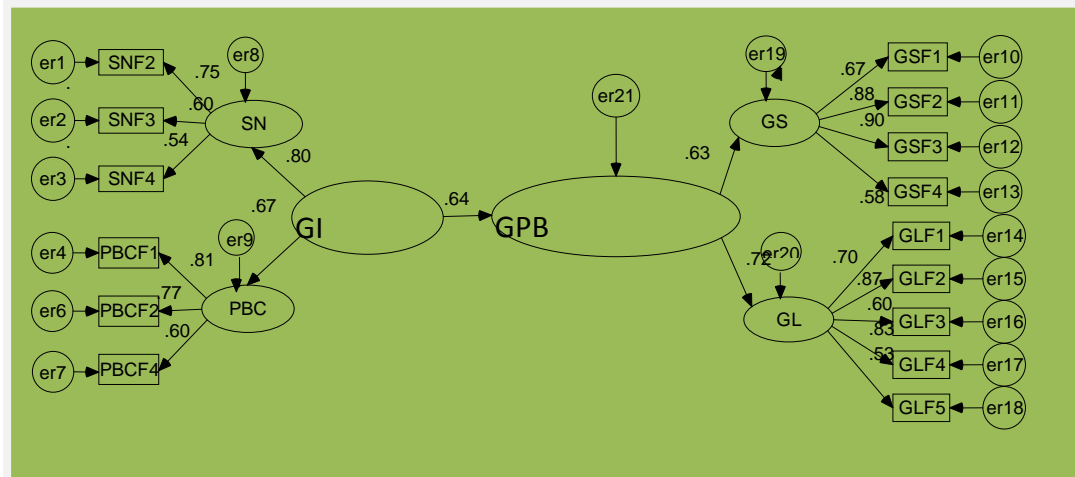

**Notes:** GI= Green intention, GPB= Green purchase behaviour, SN= Subjective norms, SNF2= Peer group influence, SNF3= Social expectations, SNF4= Reference group views, PBC= Perceived behavioural control, PBCF1= Green information, PBCF2= Ability to buy, PBCF4= Availability of products, GS= Green satisfaction, GSF1= Social contribution, GSF2= Monetary benefits, GSF3= Health benefits, GSF4= Environmental benefits, GLF1= Green performance, GLF2= Green advice, GLF3= Green choice, GLF4= Green commitments, GLF5= Green habit and er1-er21= error terms.

**H2c:** Youths’ green purchase intention mediates the link between attitude toward green products and green purchase behaviour.

The structural model (Fig. 4) portrays the mediating role of green intention between green attitude and green purchase behaviour, which is examined using SEM, based on Baron and Kenny (1986) methodology. Fig. 3 shows the direct impact of green attitude on green purchase behaviour, which is significant at 95% level. The structural model V also fitted well as depicted by chi-square/df statistics= 4.542, GFI= 0.982, AGFI= 0.951, RMR= 0.018, RMSEA= 0.063, NFI= 0.968, TLI= 0.943 and CFI= 0.975 (Table 3). The direct impact of green attitude on green purchase behaviour is significant since the P-value is 0.00 which is less than 0.05 and  $\beta$ -value is 0.86 when the mediator green intention enter the model the  $\beta$ -value between green attitude and green purchase behaviour is reduced to 0.47 but relationship is insignificant as the P-value is 0.70 (Table 2). So we can conclude that the green intention fully mediates the relationship between green attitude and green purchase behaviour as the  $\beta$ -value gets reduced but the relationship is insignificant. The result of Baron and Kenny’s (1986) four steps to test the mediating effect of green intention on the relationship between green attitude (independent variable) and green purchase behaviour (dependent variable) are summarised in the Table 2.

Figure 3: Impact of Green attitude on Green purchase behaviour

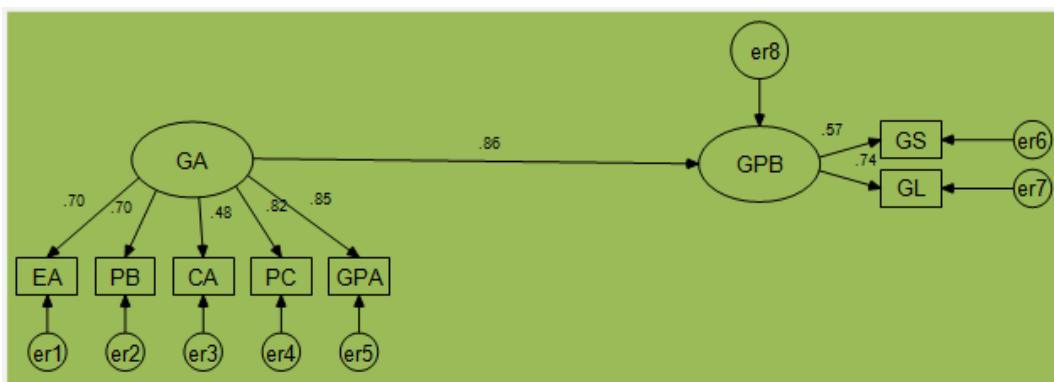

**Notes:** GA= Green attitude, EA= Environmental attitude, PB= Personal benefits, CA= Consumer awareness, PC= Psychological characteristics, GPA= Green purchase attributes, GPB= Green purchase behaviour, GS= Green satisfaction, GL= Green Loyalty and er1-er8= error terms.

**Figure 4: Structural Model III: Mediating role of Green Intention**

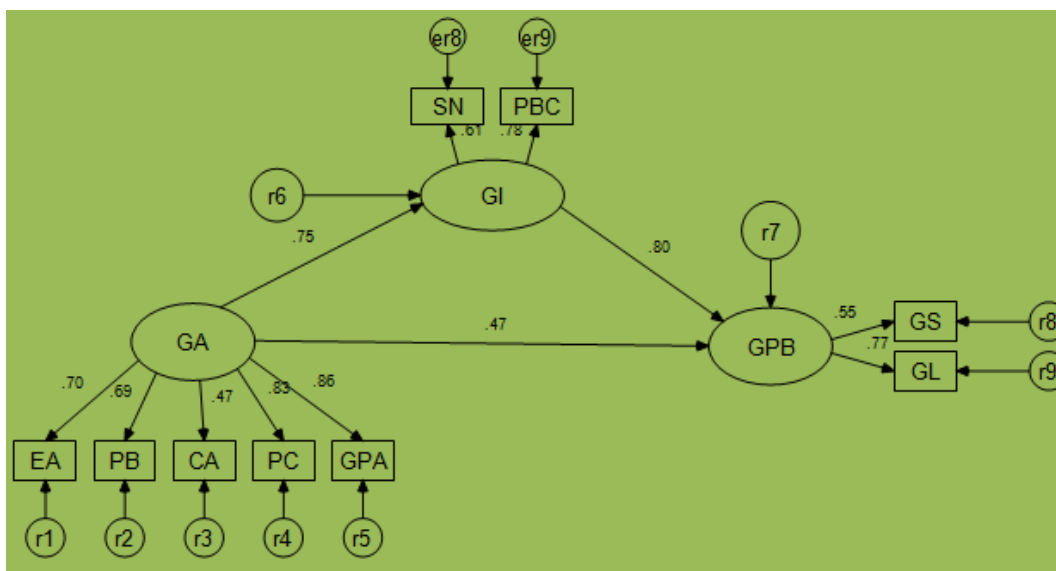

**Notes:** GA= Green attitude, EA= Environmental attitude, PB= Personal benefits, CA= Consumer awareness, PC= Psychological characteristics, GI= Green intention, SN= Subjective norms, PBC= Perceived behavioural control, GPA= Green purchase attributes, GPB= Green purchase behaviour, GS= Green satisfaction, GL= Green Loyalty and r1-r9= error terms.

**7. Discussion and Conclusion**

The outcomes of this study provide both a practical and theoretical input to the understanding of the green purchase behaviour of Indian young consumers. Certain factors like environmental attitude, personal benefits, consumer awareness, psychological characteristics and green product attributes are found to exert significant bearing on Indian young consumers’ attitudes toward green purchases, which in turn, affect their green purchase intention, and ultimately, their green purchase behaviour. These findings remind the Indian government of the importance of exploring these factors among its citizens in the course of rapid industrialization.

Expectantly, through proper educational and social marketing means, the Indian government can make better use of these various factors to advance its citizens’ environmental consciousness and achieve more sustainable national development. The study also found that green intention and ultimate green purchase behaviour are also affected by certain factors viz. subjective norms & perceived behavioural control and green satisfaction and green loyalty respectively. So the green marketers should understand all these psychological factors and try to satisfy the green needs of the consumers and make them buy the green products on regular basis.

Although the proposed model has proven to be reasonably competent in explaining young consumers’ green attitude and green purchase behaviour, but green purchase intention deserves special attention. As revealed in Figure 1, the estimated standardized regression between these two constructs (green attitude and green intention) is 0.80. This value is higher than the one between green purchases intention and green purchase behaviour i.e., 0.64.

The findings propose that although attitudes toward green purchases are translated rather efficiently into green purchase intention, the translation of green purchase intention into corresponding behaviour does not have the same degree of value.

The low correspondence between green purchase intention and actual purchase some might suggest, is attributed to the relative high price, unavailability of green products, low quality etc.

Although in terms of variety, green products are still not as widely available in India as in other developed countries and even they are highly priced for the young consumers as they are mostly dependent on their parents for the finance. Green marketers should set reasonable price for this section of the society. Figure 3 and Figure 4 displayed that the relation green attitude and green purchase behaviour is fully mediate by green intention. So it provides the insight to the researchers and green marketers that for analysing the Indian young consumers’ green behaviour they have not only to consider their green attitude but one more cognitive construct green intention. As green intention is influenced by subjective norms and perceived behavioural control, so green marketers should launch green promotion campaigns for imparting green knowledge to the society. Indian

consumers are dubious to have the same degree of green product variety as their Western counterparts; the availability of ecofriendly consumer products would still provide them with adequate opportunity to express their green concerns via corresponding behavioural responses. Moreover, from Indian consumers' viewpoint, the government should be most responsible for protecting the environment, followed by enterprises.

In view of the present study, it is suggested that the government should further firm up its environmental education to better endow citizens in how to distinguish between genuine and false environmental claims. For marketers wishing to further nurture India's green market, they should pay particular notice to the design and content of their environmental claims. Last, as Indian consumers would like to witness both the government and enterprises presume more responsibility for protecting the environment, it is advantageous for them to work more closely together to establish a complete eco certification scheme and a set of comprehensible environmental advertising guidelines. From a theoretical standpoint, the present results provide further empirical support to some of the important premises of such classic behavioural theories as the value–attitude–behaviour hierarchy, theory of planned behaviour and theory of reasoned action. By integrating cultural, psychological, and behavioural variables within the same analytical framework, the proposed model provides useful insights into various important determinants of green purchase behaviour. Unquestionably, these insights could grant a foundation for further in-depth investigation into the pro environmental behavioural process of the Indians.

## References

1. Ajzen, I. (1991). The theory of planned behavior. *Organizational Behavior and Human Decision Processes*, 50(1), 179-211.
2. Asgharian, R., Salehi, M., Saleki, Z.S., Hojabri, R. and Nikkheslat, M. (2012). Green product quality, green customer satisfaction and green customer loyalty. *International Journal of Research in Management & Technology*, 2(5), 499-503.
3. Anvar, M., and Venter, M. (2014). Attitudes and purchase behaviour of green products among generation y consumers in South Africa. *Mediterranean Journal of Social Sciences*, 5(21), 183-194.
4. Chen, T.B., and Chai, L.T. (2010). Attitude towards the environment and green products. *Management Science and Engineering*, 4(2), 27-39.
5. Chen, M. (2007). Consumer Attitudes and Purchase Intention in Relation to Organic Food in Taiwan: Moderating Effects of food-related Personality Traits. *Food Quality and Preference* 18, 1008-1021
6. D'souza, C., Taghian, M., Lamb, P., and Peretiako, R. (2007). Green decisions: demographics and consumer understanding of environmental labels. *International Journal of Consumer Studies*, 31(1), 371-376.
7. Kim, Y. (2005). Antecedents of green purchase behaviour: An examination of collectivism, environmental concern and PCE. *Advances in Consumer Research*, 32(1), 592-599.
8. Kumar, K.P, and Dr. Anand, B. (2013). A study on consumer behaviour towards eco-friendly paper. *Global Journal of Management and Business Research Administration and Management*, 13(11), 1-7.
9. Lodorfos, G., Dennis, J. (2008). Consumer Intent: In the Organic Food Market. *Journal of Food Products Marketing*, Vol. 14(2) 2008.
10. Mahapatra, S. (2013). A study on consumer's perception for green products: An empirical study from India. *International Journal of Management & Information Technology*, 7(1), 924-933.
11. Malhotra, N.K. (2007). *Marketing research: An applied orientation* (5<sup>th</sup> Ed.). Pearson Education, Delhi.
12. Ming, L.K.A., and Wai, B.T. (2013). Exploring consumers' green purchase behaviour towards online green advertising. *The Macrotheme Review*, 2(7), 60-81.
13. Mitra, D. (2014). A comparative study on green marketing effectiveness: A data envelopment approach. *Proceedings of the Second International Conference on Global Business, Economics, Finance and Social Sciences (GB14Chennai Conference)*. ISBN: 978-1-941505-14-4.
14. Pastiu, A.C. (2013). Green purchase intentions of Romanian consumers. *Apulensis Series Oeconomica*, 15(2), 750-754.
15. Peattie, K. 1992. *Green Marketing*. London: Pitman Publishing.
16. Rakesh, H.M., and Lakshmi, P. (2015). A study on green marketing and its impact on consumer behaviour. *International Journal in Management and Social Science*, 3(2), 320-326.
17. Robinson, R., Smith, Ch. (2002). Psychosocial and Demographic variables associated with consumer intention to purchase sustainably produced food as defined by the Midwest Food Alliance. *Journal of Nutrition Education and Behavior*, 34(6), 316-325.
18. Suki, M.N. (2013). Green awareness effects on consumers' purchasing decision: Some insights from Malaysia, *IJAPS*, 9(2), 49-63.

19. Tarkiainen, A., Sundqvist, S. (2005). Subjective Norms, Attitudes and Intentions of Finnish Consumers in Buying Organic Food. *British Food Journal*, 107(11), 808-822.
20. Vazifehdoust, H., Taleghani, M., Esmailpour, F., Nazari, K., and Mahdie, K. (2013). Purchasing green to become greener: Factors influence consumers' green purchasing behaviour. *Management Science Letters*, 3(1), 2489-2500.
21. Vermeir, I., & Verbeke, W. (2006). Sustainable food consumption: exploring the consumer "attitude-behavioral intention" gap. *Journal of Agricultural and Environmental Ethics*, 19(2), 169-194.
22. Wong, David, H., Claire, L., Kenneth, B.Y., & Randall, B. (2009). To trust or not to trust: The consumer's dilemma with e-banking. *Journal of Internet Business*, 2(6), 1-22.
23. Zhu, B. (2013). The impact of green advertising on consumer purchase intention of green products. *World Review of Business Research*, 3(3), 72-80.



**Table 1: Scale Purification of Attitudinal and Behavioural Purchase Intentions Among Youth Toward Green Products Using Factor Analysis**

Dimension	Factors	Statements	M.V.	S.D.	F.L.	C.	E.V.	V.E.	C.V.	A	
<b>A: Attitude Towards Green Products</b>											
Environmental Attitude (KMO=0.75)	<b>Factor 1:</b> Environmental Awareness	<b>EA9:</b> You think your participation in environmental protection activities would influence your family and friends, to participate	4.22	0.80	0.73	0.72					
		<b>EA17:</b> Recycling of waste would protect the environment	4.46	0.70	0.76	0.72					
		<b>EA18:</b> You are well aware about environmental issues and challenges	2.54	1.04	0.81	0.70					
		<b>EA19:</b> Your involvement in environmental activities today would help to save the environment for future generations	4.26	0.85	0.88	0.71					
	<b>F1</b>			<b>3.87</b>	<b>0.85</b>	<b>0.79</b>	<b>0.71</b>	<b>5.12</b>	<b>16.68</b>	<b>16.68</b>	<b>0.78</b>
	<b>Factor 2:</b> Environmental Problems	<b>EA2:</b> Changes in life styles would reduce energy consumption	4.17	0.89	0.90	0.83					
		<b>EA4:</b> Environmental problems are threatening health status of societies	4.52	0.82	0.76	0.76					
		<b>EA20:</b> You would be willing to pay a nominal increase in taxes/cess to support green movement	2.77	0.84	0.80	0.67					
	<b>F2</b>			<b>3.82</b>	<b>0.85</b>	<b>0.82</b>	<b>0.75</b>	<b>1.74</b>	<b>14.44</b>	<b>31.12</b>	<b>0.74</b>
	<b>Factor 3:</b> Environmental Protection	<b>EA3:</b> Protecting environment is your social duty	4.77	0.58	0.84	0.74					
		<b>EA6:</b> You are willing to take up responsibility to protect the environment	4.16	0.80	0.77	0.74					
		<b>EA10:</b> If you use green products, the environmental quality will improve	4.32	0.84	0.87	0.82					
	<b>F3</b>			<b>4.42</b>	<b>0.74</b>	<b>0.82</b>	<b>0.76</b>	<b>1.41</b>	<b>12.70</b>	<b>43.82</b>	<b>0.74</b>
	<b>Factor 4:</b> Environmental Degradation	<b>EA11:</b> You are extremely worried about the state of the world's environment and its consequences for future	4.05	0.87	0.69	0.63					
<b>EA12:</b> Mankind is severely affected by environmental degradation		4.30	1.04	0.82	0.78						

	<b>F4</b>		<b>4.17</b>	<b>0.96</b>	<b>0.76</b>	<b>0.71</b>	<b>1.37</b>	<b>10.52</b>	<b>54.34</b>	<b>0.90</b>
	<b>Factor5:</b> Environmental Initiatives	<b>EA5:</b> Small individual initiatives would protect the environment	4.16	0.88	0.68	0.73				
		<b>EA21:</b> Steps initiated at international level to protect the environment are adequate	2.12	1.05	0.83	0.81				
	<b>F5</b>		<b>3.14</b>	<b>0.97</b>	<b>0.75</b>	<b>0.77</b>	<b>1.12</b>	<b>10.09</b>	<b>64.44</b>	<b>0.88</b>
	<b>Factor 6:</b> Environmental Concern	<b>EA1:</b> In yours opinion, the existing environmental protection work are inadequate	3.83	0.98	0.60	0.59				
		<b>EA16:</b> Human beings are not properly utilising the limited resources of the earth	4.13	0.98	0.75	0.88				
	<b>F6</b>		<b>3.98</b>	<b>0.98</b>	<b>0.67</b>	<b>0.74</b>	<b>1.06</b>	<b>9.49</b>	<b>73.93</b>	<b>0.77</b>
Personal Benefits (KMO=0.62)	<b>Factor 1:</b> Personal Satisfaction	<b>PB1:</b> Purchasing green products make you more socially attractive	3.78	0.79	0.81	0.77				
		<b>PB2:</b> Purchasing green products do not makes you special	2.45	0.91	0.81	0.71				
		<b>PB5:</b> When you buy a green product you feel good about yourself	3.93	0.88	0.78	0.78				
		<b>PB14:</b> Green products help in saving the money in long run	3.64	1.04	0.82	0.77				
		<b>PB16:</b> Use of green product will increase life span of an individual	3.83	0.87	0.87	0.76				
	<b>F1</b>		<b>3.53</b>	<b>0.90</b>	<b>0.82</b>	<b>0.76</b>	<b>4.18</b>	<b>23.66</b>	<b>23.66</b>	<b>0.83</b>
	<b>Factor 2:</b> Health Benefits	<b>PB6:</b> You do not care even the prices of green products are high	2.64	1.13	0.75	0.65				
		<b>PB13:</b> While making purchases, you pay attention to product contents which are good for health	4.26	0.70	0.81	0.79				
		<b>PB15:</b> Green products help in maintaining long healthy life	4.14	0.63	0.82	0.74				
	<b>F2</b>		<b>3.68</b>	<b>0.82</b>	<b>0.79</b>	<b>0.72</b>	<b>1.63</b>	<b>15.14</b>	<b>38.81</b>	<b>0.88</b>
	<b>Factor 3:</b> Beneficial to Humanity	<b>PB11:</b> To you, going green can improve human health	4.32	0.70	0.91	0.78				
		<b>PB12:</b> Using green products make enough natural resources available for the humans	4.41	0.70	0.80	0.80				

	<b>F3</b>		<b>4.37</b>	<b>0.70</b>	<b>0.85</b>	<b>0.79</b>	<b>1.54</b>	<b>13.97</b>	<b>52.79</b>	<b>0.71</b>	
	<b>Factor 4:</b> Pure Natural Ingredients	<b>PB4:</b> Green products are produced with pure ingredients/materials and are better for your body	4.00	0.64	0.80	0.77					
		<b>PB9:</b> Green products have many health benefits with no side effects	2.86	0.87	0.78	0.81					
	<b>F4</b>		<b>3.43</b>	<b>0.75</b>	<b>0.79</b>	<b>0.79</b>	<b>1.41</b>	<b>11.74</b>	<b>64.53</b>	<b>0.74</b>	
Consumer Awareness (KMO=0.64)	<b>Factor 1:</b> Green Advertising	<b>CA1:</b> You have more confidence in advertised green products than in unadvertised green ones	3.88	0.76	0.69	0.78					
		<b>CA5:</b> You would pay more for products or services that are advertised as being green	4.25	0.96	0.86	0.85					
		<b>CA7:</b> Green advertising presents a true picture of the product being advertised	4.30	0.80	0.85	0.76					
		<b>CA12:</b> Products and services that are advertised as green are safer to use	4.00	0.75	0.82	0.74					
		<b>CA13:</b> Green advertising is good at addressing environmental problems	3.95	0.86	0.75	0.72					
		<b>CA14:</b> Green advertising is a good source of information about products/services	4.10	0.81	0.73	0.63					
		<b>F1</b>		<b>4.08</b>	<b>0.82</b>	<b>0.78</b>	<b>0.75</b>	<b>5.12</b>	<b>18.75</b>	<b>18.75</b>	<b>0.84</b>
		<b>Factor2:</b> Individual's Nature Awareness	<b>CA8:</b> It is easy for you to identify green products	3.75	0.83	0.74	0.73				
			<b>CA15:</b> Humans must live in harmony with nature in order to sustain	3.83	0.83	0.80	0.74				
			<b>CA16:</b> You are worried about impact of individual activities on environment	3.71	1.00	0.74	0.65				
		<b>F2</b>		<b>3.76</b>	<b>0.88</b>	<b>0.76</b>	<b>0.71</b>	<b>2.09</b>	<b>14.36</b>	<b>33.11</b>	<b>0.72</b>
		<b>Factor 3:</b> Eco- Labels	<b>CA18:</b> While purchasing, you read labels to see if contents are environmentally safe	3.66	0.82	0.77	0.82				
			<b>CA19:</b> You are more likely to buy green products that are labelled as eco-friendly and recycling	2.34	0.91	0.75	0.59				
			<b>CA20:</b> You prefer products with eco-								

		labelled packages	4.05	0.59	0.88	0.83				
	<b>F3</b>		<b>3.35</b>	<b>0.77</b>	<b>0.80</b>	<b>0.75</b>	<b>1.87</b>	<b>12.59</b>	<b>45.70</b>	<b>0.71</b>
	<b>Factor 4:</b> Green Movement	<b>CA2:</b> Environmental friendly products are very popular due to green movement	2.35	0.82	0.76	0.54				
		<b>CA3:</b> By buying a green product, you indirectly influence the environmental protection	3.95	0.73	0.81	0.78				
		<b>CA9:</b> Due to green movement you plan to switch to green products and services	3.64	0.79	0.81	0.75				
		<b>CA17:</b> Green products/services are less expensive to society in the long run	2.69	0.91	0.82	0.67				
	<b>F4</b>		<b>3.16</b>	<b>0.81</b>	<b>0.80</b>	<b>0.69</b>	<b>1.58</b>	<b>11.03</b>	<b>56.74</b>	<b>0.84</b>
Psychological Characteristics (KMO=0.62)	<b>Factor 1:</b> Unselfishness	<b>PC1:</b> You have an unselfish attitude so as to think about the welfare of the mankind	3.89	1.01	0.79	0.67				
		<b>PC2:</b> You think it is important to protect the earth for the next generation	4.45	0.67	0.81	0.65				
		<b>PC7:</b> When you buy products, you consider their impact on environment and on other consumers	3.40	0.94	0.73	0.68				
		<b>PC8:</b> With green products, you have the feeling of contributing to the well-being of humanity and nature	4.00	0.96	0.81	0.71				
		<b>PC9:</b> When you think of the ways industries are causing pollution, you get frustrated and angry	2.99	0.94	0.75	0.50				
	<b>F1</b>		<b>3.75</b>	<b>0.90</b>	<b>0.78</b>	<b>0.64</b>	<b>3.81</b>	<b>19.93</b>	<b>19.93</b>	<b>0.85</b>
	<b>Factor 2:</b> Future-oriented	<b>PC10:</b> It frightens you to think that limited natural resources may not be available for future generations	4.02	0.96	0.89	0.76				
		<b>PC12:</b> Each individual should do something about environment protection	4.26	0.77	0.91	0.84				
		<b>PC14:</b> We should do our best efforts to save limited natural resources from being used up	4.27	0.85	0.86	0.80				
	<b>F2</b>		<b>4.18</b>	<b>0.86</b>	<b>0.88</b>	<b>0.80</b>	<b>2.39</b>	<b>14.02</b>	<b>33.95</b>	<b>0.77</b>
<b>Factor 3:</b>	<b>PC11:</b> You feel you have personal									

	Altruism	control over the solution to the energy problem	3.91	1.15	0.82	0.73					
		<b>PC13:</b> It is worthless for the individual consumer to do anything about pollution	2.73	1.34	0.85	0.79					
		<b>PC16:</b> As your personal needs are satisfied, now you are worried about the environment	3.45	1.02	0.80	0.59					
	<b>F3</b>		<b>3.36</b>	<b>1.17</b>	<b>0.82</b>	<b>0.70</b>	<b>1.77</b>	<b>13.77</b>	<b>47.73</b>	<b>0.80</b>	
	<b>Factor 4:</b> Perceived consumer effectiveness	<b>PC3:</b> There is so much to be done for environmental protection that any one individual cannot do alone	4.40	0.85	0.71	0.78					
		<b>PC4:</b> The conservation efforts of one person are useless as long as other people refuse to conserve	3.86	1.24	0.80	0.65					
		<b>PC5:</b> You feel personally hopeful to have much of an impact on a problem as large as the environment protection	3.56	1.04	0.74	0.73					
	<b>F4</b>		<b>3.94</b>	<b>1.04</b>	<b>0.75</b>	<b>0.72</b>	<b>1.34</b>	<b>12.20</b>	<b>59.93</b>	<b>0.75</b>	
	Green Product Attributes (KMO=0.73)	<b>Factor 1:</b> Eco-friendly and Healthy contents	<b>GPA3:</b> Green products are easy to recycle, disassemble, decompose and reuse	4.25	0.69	0.86	0.85				
			<b>GPA4:</b> Green products result in minimum environmental damage	3.71	0.58	0.87	0.79				
<b>GPA7:</b> Raw materials used in green products are of good quality			4.02	0.75	0.72	0.62					
<b>GPA8:</b> Green products are safer to use in terms of health and environment			3.81	0.60	0.76	0.73					
<b>F1</b>			<b>3.95</b>	<b>0.66</b>	<b>0.80</b>	<b>0.75</b>	<b>6.07</b>	<b>17.26</b>	<b>17.26</b>	<b>0.84</b>	
<b>Factor 2:</b> Economical		<b>GPA2:</b> Green products offer value for money	3.77	0.83	0.72	0.83					
		<b>GPA15:</b> Green products are reasonably priced	3.65	1.00	0.90	0.83					
		<b>GPA18:</b> Green products are economical	3.72	0.84	0.86	0.82					
<b>F2</b>			<b>3.71</b>	<b>0.89</b>	<b>0.83</b>	<b>0.83</b>	<b>2.18</b>	<b>15.86</b>	<b>33.12</b>	<b>0.83</b>	
<b>Factor 3:</b> Good taste and quality		<b>GPA1:</b> Green products meet or exceed the requirements of environmental regulations	2.10	0.78	0.79	0.74					

		<b>GPA9:</b> When making purchases you would primarily buy green products which taste good	1.90	0.86	0.86	0.79				
		<b>GPA12:</b> Green products have an acceptable standard of quality	4.02	0.70	0.81	0.51				
		<b>GPA14:</b> Green products have consistent quality	3.87	0.73	0.83	0.81				
	<b>F3</b>		<b>2.97</b>	<b>0.77</b>	<b>0.82</b>	<b>0.71</b>	<b>1.46</b>	<b>15.72</b>	<b>48.84</b>	<b>0.80</b>
	<b>Factor 4:</b> Energy-efficient	<b>GPA16:</b> Green products consume the least amount of resources and energy	3.91	0.73	0.73	0.58				
		<b>GPA17:</b> Green products are certified for authenticity	3.97	0.60	0.79	0.84				
		<b>GPA19:</b> Green products are energy efficient	4.31	0.56	0.79	0.73				
	<b>F4</b>		<b>4.06</b>	<b>0.63</b>	<b>0.77</b>	<b>0.72</b>	<b>1.20</b>	<b>14.09</b>	<b>62.93</b>	<b>0.74</b>
	<b>Factor 5:</b> Green packaging	<b>GPA5:</b> Packaging of green products is made of recycled or recyclable materials	4.21	0.84	0.84	0.82				
		<b>GPA6:</b> Packaging of green products is produced without the use of plastics	3.83	0.99	0.85	0.79				
	<b>F5</b>		<b>4.02</b>	<b>0.92</b>	<b>0.85</b>	<b>0.81</b>	<b>1.16</b>	<b>12.51</b>	<b>75.43</b>	<b>0.80</b>
<b>B. Intention To Buy Green Products</b>										
Subjective Norms (KMO=0.62)	<b>Factor 1:</b> Family views	<b>SN6:</b> People who are important to you would think that you should use green products	3.37	0.82	0.71	0.63				
		<b>SN7:</b> Your parents influence you to purchase a green product	3.29	0.94	0.75	0.70				
		<b>SN14:</b> Most people like you to buy green products	3.36	0.97	0.78	0.75				
		<b>SN15:</b> Most of your family members approve of your decisions to buy green products	4.43	0.96	0.91	0.68				
	<b>F1</b>		<b>3.61</b>	<b>0.92</b>	<b>0.78</b>	<b>0.69</b>	<b>4.56</b>	<b>20.56</b>	<b>20.56</b>	<b>0.83</b>
	<b>Factor 2:</b> Peer group influence	<b>SN8:</b> Your peer group influence you to buy green products	4.35	1.10	0.85	0.82				
		<b>SN9:</b> Your peer group approve you to buy green products	3.20	1.09	0.80	0.77				
			<b>SN10:</b> You feel social pressure to buy green products	2.42	1.17	0.79	0.66			

	<b>F2</b>		<b>3.32</b>	<b>4.45</b>	<b>0.81</b>	<b>0.75</b>	<b>2.10</b>	<b>20.03</b>	<b>40.60</b>	<b>0.85</b>
	<b>Factor 3:</b> Social expectations	<b>SN11:</b> You try to pay attention to the reactions of others toward your behaviour about the green products	2.68	1.25	0.85	0.77				
		<b>SN12:</b> It's important for you to fit into the green group you are with	4.02	1.13	0.83	0.80				
		<b>SN13:</b> Your behaviour often depends on how you feel others wish you to behave about the green products	4.08	1.03	0.82	0.83				
	<b>F3</b>		<b>3.59</b>	<b>1.14</b>	<b>0.83</b>	<b>0.80</b>	<b>2.03</b>	<b>18.10</b>	<b>56.69</b>	<b>0.81</b>
	<b>Factor 4:</b> Reference group views	<b>SN2:</b> Positive views of your reference group develops your intention to buy green products	3.70	0.89	0.81	0.79				
		<b>SN3:</b> You respect decisions made by your group about the usage of green products	3.95	0.78	0.71	0.71				
		<b>SN4:</b> Green product users influence you often think that buying green is a good idea	4.24	0.71	0.96	0.84				
	<b>F4</b>		<b>3.96</b>	<b>0.79</b>	<b>0.82</b>	<b>0.78</b>	<b>1.04</b>	<b>16.19</b>	<b>74.88</b>	<b>0.78</b>
Perceived Behavioural Control (KMO=0.78)	<b>Factor 1:</b> Green information	<b>PBC7:</b> You are confident that you are capable of indentifying and buying green products	3.58	0.74	0.87	0.77				
		<b>PBC8:</b> You know where to buy green products	3.61	0.76	0.76	0.76				
		<b>PBC12:</b> You have the resources, knowledge and the ability to buy the green products	3.46	0.84	0.75	0.72				
		<b>PBC17:</b> You have sufficient time to purchase environmental friendly products	2.20	0.88	0.72	0.64				
		<b>PBC18:</b> You have sufficient information and knowledge on environmental friendly products	3.33	0.97	0.83	0.77				
	<b>F1</b>		<b>3.25</b>	<b>0.84</b>	<b>0.79</b>	<b>0.73</b>	<b>4.29</b>	<b>25.04</b>	<b>25.04</b>	<b>0.87</b>
	<b>Factor 2:</b> Ability to buy	<b>PBC1:</b> You have an adequate amount of money to buy the green products	2.24	0.81	0.88	0.52				

		<b>PBC2:</b> Green products are difficult to buy	3.97	1.10	0.96	0.82				
		<b>PBC6:</b> You consider it acceptable to spend some extra money in order to purchase green products	3.17	1.06	0.81	0.71				
		<b>PBC16:</b> For you to get green products is convenient and easy	1.08	1.21	0.72	0.61				
	<b>F2</b>		<b>2.62</b>	<b>1.05</b>	<b>0.84</b>	<b>0.67</b>	<b>2.41</b>	<b>16.29</b>	<b>41.34</b>	<b>0.73</b>
	<b>Factor 3:</b> Time	<b>PBC10:</b> You can buy green products without spending much time	3.50	0.87	0.74	0.75				
		<b>PBC11:</b> You think you have all the time you need to buy green products	3.25	0.87	0.87	0.84				
	<b>F3</b>		<b>3.38</b>	<b>0.87</b>	<b>0.81</b>	<b>0.80</b>	<b>1.40</b>	<b>12.49</b>	<b>53.83</b>	<b>0.81</b>
	<b>Factor 4:</b> Availability of products	<b>PBC3:</b> Green products are available only in few outlets	4.00	1.05	0.94	0.83				
		<b>PBC5:</b> You have to visit multiple stores to do your shopping for green products	4.28	0.93	0.73	0.74				
	<b>F4</b>		<b>4.14</b>	<b>0.99</b>	<b>0.84</b>	<b>0.78</b>	<b>1.14</b>	<b>10.92</b>	<b>64.76</b>	<b>0.76</b>
<b>C. Green Purchase Behaviour</b>										
Green Satisfaction (KMO=0.67)	<b>Factor 1:</b> Social contribution	<b>GS11:</b> Buying green products gives you a better standing with in your social circle	3.72	0.99	0.79	0.53				
		<b>GS12:</b> Your choice to purchase green products was a wise one	4.06	0.70	0.76	0.74				
		<b>GS13:</b> You believe that by purchasing the green products you are contributing towards society	4.60	0.63	0.83	0.61				
		<b>GS14:</b> You have purchased products because they cause less pollution to the society	4.08	0.77	0.91	0.80				
	<b>F1</b>		<b>4.12</b>	<b>0.77</b>	<b>0.82</b>	<b>0.67</b>	<b>4.55</b>	<b>19.39</b>	<b>19.39</b>	<b>0.82</b>
	<b>Factor 2:</b> Monetary benefits	<b>GS16:</b> Green practices allow you to save money	4.11	0.65	0.89	0.77				
		<b>GS17:</b> You would accept paying extra price for environmentally-friendly products to preserve your environment	3.97	0.70	0.79	0.73				
<b>GS18:</b> Purchasing green products is more economical		1.76	0.89	0.83	0.78					



	<b>F2</b>		<b>3.28</b>	<b>0.75</b>	<b>0.84</b>	<b>0.76</b>	<b>2.41</b>	<b>16.21</b>	<b>35.60</b>	<b>0.74</b>
	<b>Factor 3:</b> Positive health outcomes	<b>GS2:</b> You will not buy a product if the company that sells it is ecologically irresponsible	2.80	0.84	0.73	0.59				
		<b>GS3:</b> You are happy about your decision to choose green product because of its positive health outcomes	4.11	0.64	0.81	0.59				
		<b>GS6:</b> You are satisfied with green product because of its human health concern	4.38	0.57	0.75	0.57				
		<b>GS10:</b> Green products are better in health-wise quality	3.88	0.82	0.72	0.56				
	<b>F3</b>		<b>3.79</b>	<b>0.72</b>	<b>0.75</b>	<b>0.58</b>	<b>1.73</b>	<b>15.83</b>	<b>51.43</b>	<b>0.71</b>
	<b>Factor 4:</b> Environmental benefits	<b>GS1:</b> Practicing green consumption is like contributing towards environment protection	3.47	1.03	0.85	0.77				
		<b>GS4:</b> Green products are superior in performance to non-green products	2.24	0.61	0.77	0.69				
		<b>GS5:</b> You are satisfied with the green product because it is environmentally friendly	4.45	0.71	0.80	0.58				
		<b>GS7:</b> You are satisfied with you decision to purchase the green products	4.12	0.73	0.73	0.64				
	<b>F4</b>		<b>3.57</b>	<b>0.77</b>	<b>0.79</b>	<b>0.67</b>	<b>1.27</b>	<b>14.92</b>	<b>66.35</b>	<b>0.77</b>
Green Loyalty (KMO=0.65)	<b>Factor 1:</b> Green performance	<b>GL3:</b> You prefer purchasing green product to other products because of its environmental performance	4.10	0.62	0.78	0.66				
		<b>GL9:</b> You prefer to repurchase an environmentally safe product even if it is somewhat more expensive	2.61	0.99	0.80	0.74				
		<b>GL11:</b> You would be willing to switch brands for one that is more environmentally friendly	3.76	0.84	0.83	0.61				
		<b>GL12:</b> Green products keep promises and commitments for environmental protection	3.98	0.58	0.81	0.68				
		<b>GL13:</b> You buy the green products because you want to, not because you	3.79	0.90	0.71	0.60				

	have to									
<b>F1</b>		<b>3.65</b>	<b>0.79</b>	<b>0.79</b>	<b>0.66</b>	<b>5.06</b>	<b>19.98</b>	<b>19.98</b>	<b>0.94</b>	
<b>Factor 2:</b> Green advice	<b>GL4:</b> You seldom advise others to switch to other products because of green product's environmental concern	2.66	0.95	0.76	0.76					
	<b>GL5:</b> You recommend the green products to someone who seeks your advice	4.58	0.74	0.92	0.84					
	<b>GL6:</b> You are willing to recommend your family and friends to buy green products	4.02	0.77	0.82	0.73					
<b>F2</b>		<b>3.75</b>	<b>0.82</b>	<b>0.83</b>	<b>0.78</b>	<b>2.11</b>	<b>14.89</b>	<b>34.88</b>	<b>0.85</b>	
<b>Factor 3:</b> Green choice	<b>GL1:</b> Given the choice between two equal products, you purchase the one less harmful to other people and the environment	4.36	0.84	0.70	0.80					
	<b>GL8:</b> You use green products because it is the best choice for you	3.92	0.68	0.85	0.84					
	<b>GL15:</b> In comparison to non-green products you know, the green products are growing in popularity	3.89	0.80	0.82	0.79					
<b>F3</b>		<b>4.05</b>	<b>0.77</b>	<b>0.79</b>	<b>0.81</b>	<b>1.86</b>	<b>13.77</b>	<b>48.65</b>	<b>0.87</b>	
<b>Factor 4:</b> Green commitments	<b>GL14:</b> You are committed to buy the green products	3.81	0.73	0.90	0.70					
	<b>GL16:</b> If the green products are not available, it makes a great difference to me	3.68	0.77	0.82	0.73					
	<b>GL17:</b> You have repeatedly found the green products better than others	4.65	0.74	0.81	0.73					
<b>F4</b>		<b>4.04</b>	<b>0.75</b>	<b>0.84</b>	<b>0.72</b>	<b>1.52</b>	<b>12.18</b>	<b>60.83</b>	<b>0.88</b>	
<b>Factor 5:</b> Green habit	<b>GL10:</b> You prefer to repurchase an environmentally safe product even if it is somewhat lower in quality	2.59	1.09	0.87	0.84					
	<b>GL19:</b> When you see a new product, somewhat different from green product, you will not try it	3.22	1.00	0.75	0.65					
<b>F5</b>		<b>2.90</b>	<b>1.05</b>	<b>0.81</b>	<b>0.75</b>	<b>1.10</b>	<b>11.99</b>	<b>72.82</b>	<b>0.71</b>	
<b>Notes:</b> M.V. = Mean value, C = Communality, KMO = Kaiser-Miller-Olkin, S.D. = Standard deviation, F.L. = Factor loading, V.E. = Variance explained, E.V. = Eigen value, C.V. = Cumulative variance and A = Alpha value.										

**Table 2: Impact of Green attitude on Green purchase behaviour: Mediating role of Green intention**

Step	Independent variable	Dependent variable	Significance of relationship	SRW ( $\beta$ -value)	P.V
1	Green attitude	Green purchase behaviour	Significant	0.86	0.00
2	Green attitude	Green intention	Significant	0.75	0.02
3	Green intention	Green purchase behaviour	Insignificant	0.80	0.11
4	Green attitude	Green intention (mediator) and Green purchase behaviour	Reduced but insignificant (Direct relationship after addition of mediator)	0.32	0.70

**Table 3: Overall Fitness of Hypotheses Tested**

Fitness-index	Structural model I	Structural model II	Structural model III
Chi-square/df	3.962	4.734	4.542
GFI	0.987	0.968	0.982
AGFI	0.946	0.922	0.951
RMR	0.036	0.032	0.018
RMSEA	0.054	0.064	0.063
NFI	0.964	0.951	0.968
TLI	0.939	0.915	0.943
CFI	0.955	0.960	0.975

**Notes:** GFI= Goodness-of-fit index, AGFI= Adjusted Goodness-of-fit indices, RMR= Root Mean Square, RMSEA= Root Mean Square Error of Approximation, NFI= Normed Fit Index, TLI= Tucker Lewis Index and CFI= Comparative Fit Index